

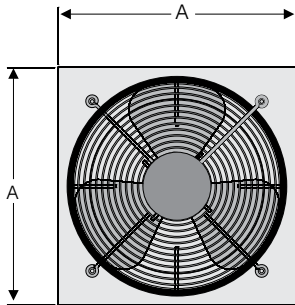

P: 866.733.0233  
www.solerpalaucanada.com

# MODEL GED/GSD DIRECT DRIVE SIDEWALL PROPELLER FAN WITH INTEGRAL OSHA GUARD



REAR VIEW

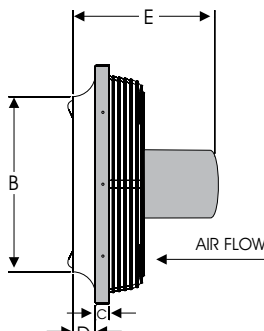

EXHAUST

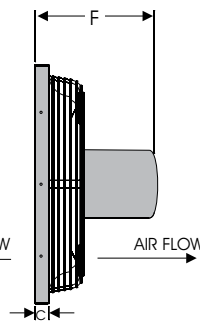

SUPPLY

### STANDARD CONSTRUCTION FEATURES

- Galvanized steel G90 panel assembly.
- Statically and dynamically balanced aluminum blades.
- Integral OSHA approved motor side guard.
- One piece spun venturi for maximum efficiency.
- Pre-punched mounting holes for easy installation.
- Unit suitable for all-angle construction.
- cULus Listed - Standard 705 (optional)



GED/GSD Size	Dimensions (in.)						Avg. Ship Wt. (lbs.)
	A	B	C	D	E*	F*	
10	16	10-1/2	1	2	11	9	30
12	16	12-1/2	1	2	14	12	30
14	20	14-1/2	1	2	14	12	34
16	20	16-1/2	1	2	14	12	37
18	24	18-1/2	1	2	15	13	45
20	24	20-1/2	1	2	15	13	50

- A. Outside dimension of square panel.
- B. Diameter of venturi.
- C. Width of flange, 1" for all models.
- D. Depth of venturi, 2" for all models.
- E. Depth of fan (exhaust).
- F. Depth of fan (supply).
- \* Varies with motor selection.

FAN SPECIFICATIONS									MOTOR SPECIFICATIONS				
Line	Qty.	Model No.	Tag	CFM	SP	Fan RPM	BHP	Sones	HP	Volts	Phase	Hertz	Encl
1													
2													
3													
4													
5													

ACCESSORY ITEMS	1	2	3	4	5	ACCESSORY ITEMS	1	2	3	4	5
<input type="checkbox"/>						<input type="checkbox"/>					
<input type="checkbox"/>						<input type="checkbox"/>					
<input type="checkbox"/>						<input type="checkbox"/>					
<input type="checkbox"/>						<input type="checkbox"/>					
<input type="checkbox"/>						<input type="checkbox"/>					

Project: \_\_\_\_\_ Submitted: \_\_\_\_\_  
 Customer: \_\_\_\_\_ Approved: \_\_\_\_\_  
 Location: \_\_\_\_\_

Subject to change unless approved in submittal by S&P.  
GED-GSD\_Submittal\_0107





P: 866.733.0233  
www.solerpalaucanada.com

# MODEL DDE/DDS DIRECT DRIVE SIDEWALL PROPELLER FAN

## STANDARD CONSTRUCTION FEATURES

- Galvanized steel G90 panel assembly.
- Welded schedule 40 galvanized pipe support structure.
- Statically and dynamically balanced aluminum blades.
- Precision spun orifice for smooth performance.
- Pre-punched mounting holes for easy installation.
- Permanently lubricated sealed ball bearing motors.
- Unit suitable for all-angle construction.

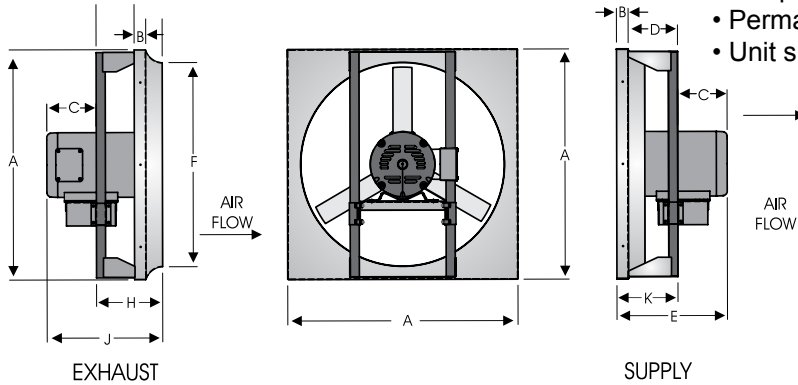

DDE/ DDS Size	Dimensions (in.)										
	A	B	C*	D	E*	F	G	H	I	J	K
24	30	2	11	9	21	25	3	9	4	20	11
30	36	2	11	9	21	31	3	9	4	20	11
36	42	2	11	9	21	37	3	9	4	20	11
42	48	2	11	9	21	43	3	9	4	20	11
48	54	2	12	10	23	49-1/4	4	10	4	22	12
54	60	2	13	11	25	55-1/4	5	11	4	24	13
60	66	2	13	11	25	61-1/4	5	11	4	24	13

- A. Outside dimension of square panel.
- B. Width of flange.
- C. Depth of motor beyond support structure.\*
- D. Depth of support structure - supply.
- E. Depth of fan - supply.\*
- F. Diameter of venturi.
- G. Depth of venturi.
- H. Depth of panel and support structure - exhaust.
- I. Depth of support structure - exhaust.
- J. Depth of fan - exhaust.\*
- K. Depth of panel and support structure - supply.
- \* Varies with motor selection

FAN SPECIFICATIONS										MOTOR SPECIFICATIONS				
Line	Qty.	Model No.	Tag	CFM	SP	Fan RPM	BHP	Sones	HP	Volts	Phase	Hertz	Encl	
1														
2														
3														
4														
5														

ACCESSORY ITEMS	1	2	3	4	5	ACCESSORY ITEMS	1	2	3	4	5
<input type="checkbox"/>						<input type="checkbox"/>					
<input type="checkbox"/>						<input type="checkbox"/>					
<input type="checkbox"/>						<input type="checkbox"/>					
<input type="checkbox"/>						<input type="checkbox"/>					
<input type="checkbox"/>						<input type="checkbox"/>					

Project: \_\_\_\_\_ Submitted: \_\_\_\_\_  
 Customer: \_\_\_\_\_ Approved: \_\_\_\_\_  
 Location: \_\_\_\_\_



P: 866.733.0233  
www.solerpalaucanada.com

# MODEL DFE/DFS DIRECT DRIVE SIDEWALL PROPELLER FAN

## STANDARD CONSTRUCTION FEATURES

- Galvanized steel G90 panel assembly.
- Welded schedule 40 galvanized pipe support structure.
- Statically and dynamically balanced aluminum blades.
- Precision spun orifice for smooth performance.
- Pre-punched mounting holes for easy installation.
- Permanently lubricated sealed ball bearing motors.
- Unit suitable for all-angle construction

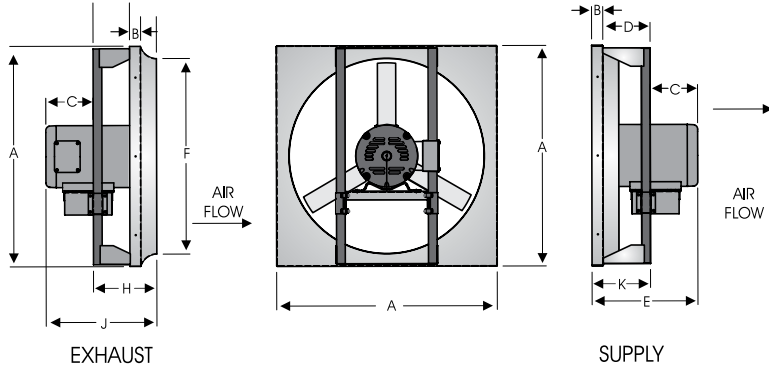

DFE/DFS Size	Dimensions (in.)											Avg. Ship Wt. (lbs.)
	A	B	C*	D	E*	F	G	H	I	J*	K	
10	16	1	6	6	11	10-1/2	2	8	5	14	7	30
12	16	1	6	6	11	12-1/2	2	8	5	14	7	30
16	20	1	6	6	12	16-1/2	2	8	5	14	7	37
18	24	1	6	6	12	18-1/2	2	8	5	14	7	45
20	24	1	7	6	12	20-1/2	2	8	5	15	7	50
24	30	2	10	9	21	25	3	10	4	20	11	70
30	36	2	10	9	21	31	3	10	4	20	11	100

- A. Outside dimension of square panel.
  - B. Width of flange.
  - C. Depth of motor beyond support structure.\*
  - D. Depth of support structure - supply.
  - E. Depth of fan - supply. \*
  - F. Diameter of venturi.
  - G. Depth of venturi.
  - H. Depth of panel and support structure - exhaust.
  - I. Depth of support structure - exhaust.
  - J. Depth of fan - exhaust.\*
  - K. Depth of panel and support structure - supply.
- \* Varies with motor selection

FAN SPECIFICATIONS										MOTOR SPECIFICATIONS				
Line	Qty.	Model No.	Tag	CFM	SP	Fan RPM	BHP	Sones	HP	Volts	Phase	Hertz	Encl	
1														
2														
3														
4														
5														

ACCESSORY ITEMS	1	2	3	4	5	ACCESSORY ITEMS	1	2	3	4	5
<input type="checkbox"/>						<input type="checkbox"/>					
<input type="checkbox"/>						<input type="checkbox"/>					
<input type="checkbox"/>						<input type="checkbox"/>					
<input type="checkbox"/>						<input type="checkbox"/>					
<input type="checkbox"/>						<input type="checkbox"/>					

Project: \_\_\_\_\_ Submitted: \_\_\_\_\_  
 Customer: \_\_\_\_\_ Approved: \_\_\_\_\_  
 Location: \_\_\_\_\_

Subject to change unless approved in submittal by S&P.  
DFE-DFS\_Submittal\_0107

